



# Pneumatic Fenders.

## Characteristics

- ▶ Proportional increase of energy and reaction
- ▶ Low hull pressure
- ▶ Economical solution
- ▶ Easily deflateable to be used in different locations and to be stored on deck of vessels
- ▶ Built as per I SO 17357-1:2014

## Applications

- ▶ In ports with extreme tidal variations
- ▶ Ship-to-ship lightering operations
- ▶ Oil & Gas (typically F SRU)
- ▶ Temporary berthing

## PNEUMATIC FENDER DIMENSIONS AND PERFORMANCE VALUES

Fender Size D x L  [mm]	Initial Pressure 0.5 kg / cm <sup>2</sup>			Initial Pressure 0.8 kg / cm <sup>2</sup>			Weight		
	Guaranteed energy absorption (GEA) [kNm]	Reaction force at GEA deflection [kN]	Hull pressure at GEA deflection [kN/m <sup>2</sup> ]	Guaranteed energy absorption (GEA) [kNm]	Reaction force at GEA deflection [kN]	Hull pressure at GEA deflection [kN/m <sup>2</sup> ]	Fender Body [kg]	Chain net [kg]	Total* [kg]
500 x 1,000	6	64	132	8	85	174	25	55	80
600 x 1,000	8	74	126	11	98	166	30	65	95
700 x 1,500	17	137	135	24	180	177	45	100	145
1,000 x 1,500	32	182	122	45	239	160	60	110	170
1,000 x 2,000	45	257	132	63	338	174	75	150	225
1,200 x 2,000	63	297	126	88	390	166	110	180	290
1,350 x 2,500	102	427	130	142	561	170	170	210	380
1,500 x 3,000	153	579	132	214	761	174	220	400	620
1,700 x 3,000	191	639	128	267	840	168	250	520	770
2,000 x 3,500	308	875	128	430	1,150	168	360	670	1,030
2,500 x 4,000	663	1,381	137	925	1,815	180	650	830	1,480
2,500 x 5,500	943	2,019	148	1,317	2,653	195	860	1,050	1,910
3,300 x 4,500	1,175	1,884	130	1,640	2,476	171	1,100	1,600	2,700
3,300 x 6,500	1,814	3,015	146	2,532	3,961	191	1,660	2,300	3,960
3,300 x 10,600	3,067	5,257	158	4,281	6,907	208	3,000	4,700	7,700
4,500 x 9,000	4,752	5,747	146	6,633	7,551	192	3,800	3,680	7,480
4,500 x 12,000	6,473	7,984	154	9,037	10,490	202	7,000	8,570	15,570

\*Total weight (fender body including chain & tire net)

### GENERIC PERFORMANCE CURVE PNEUMATIC FENDERS

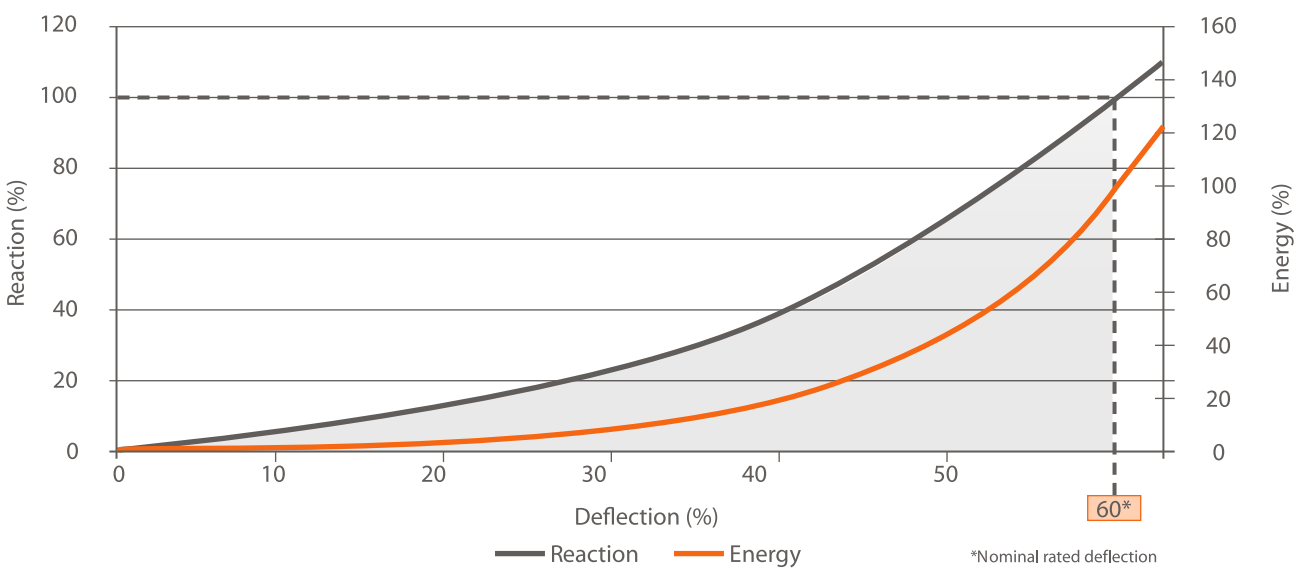

SLING-TYPE DRAWING

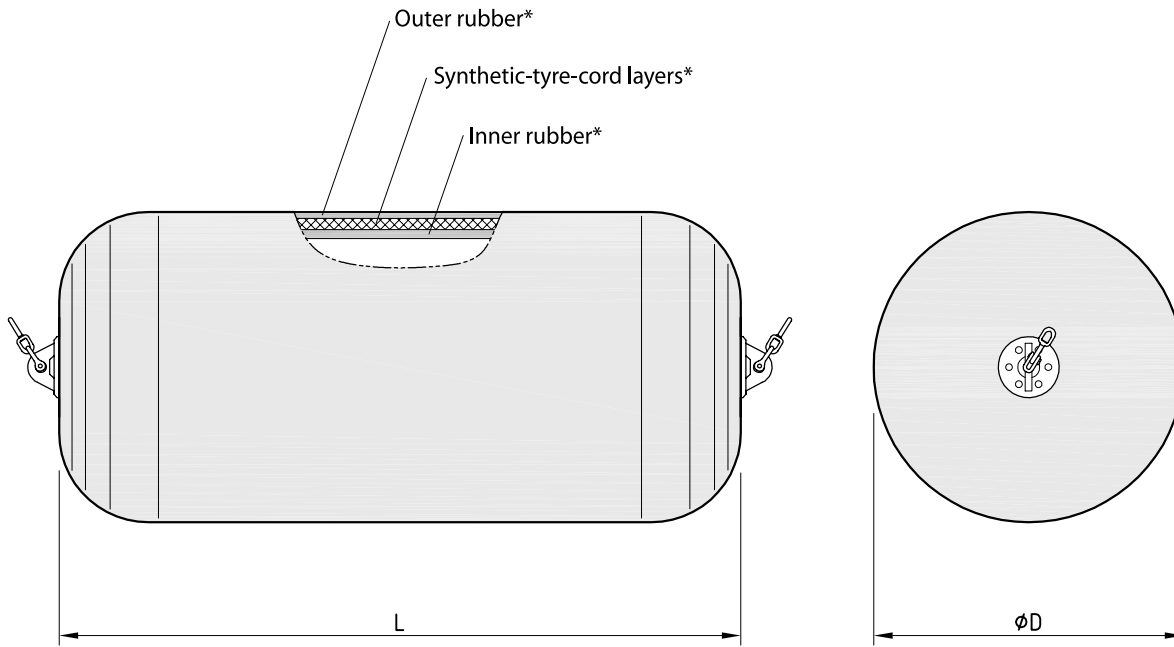

\*Not to scale



Navy Training Ship 'Buque Escuela BAP UNION' | Peru



Navy Base | Guam | U SA

CHAIN & TIRE NET TYPE DRAWING

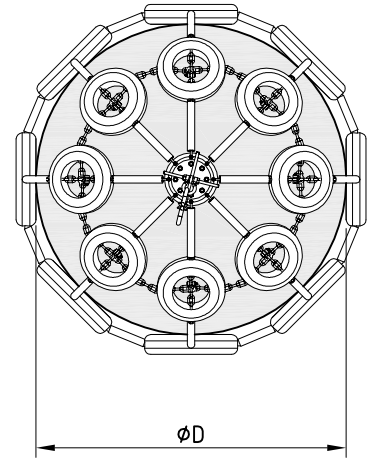
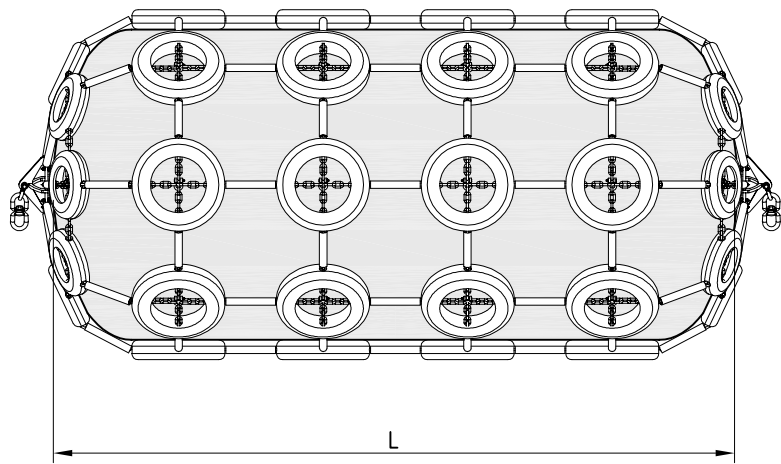

Ponto Colombo T7 | Genova | Italy



Cruise Terminal | Rostock | Germany