



Extruded Fenders.

Characteristics

- ▶ Simple & easy installation
- ▶ Customized sizes
- ▶ Wide range of applications

Applications

- ▶ Marinas
- ▶ Multipurpose fendering
- ▶ Tug Boats and Workboats
- ▶ Small boat berths

TYPICAL FIXING DETAILS

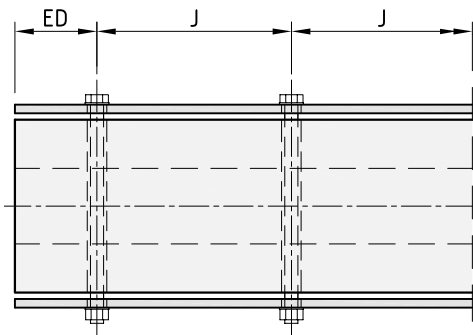
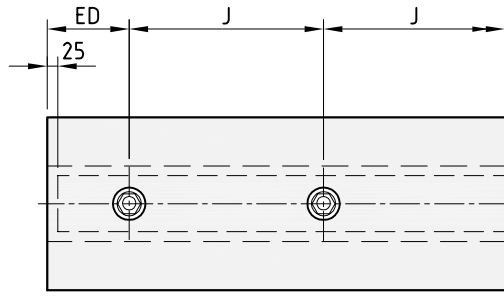

Husavik | Iceland



Den Helder | The Netherlands

GENERIC PERFORMANCE CURVE EXTRUDED FENDERS

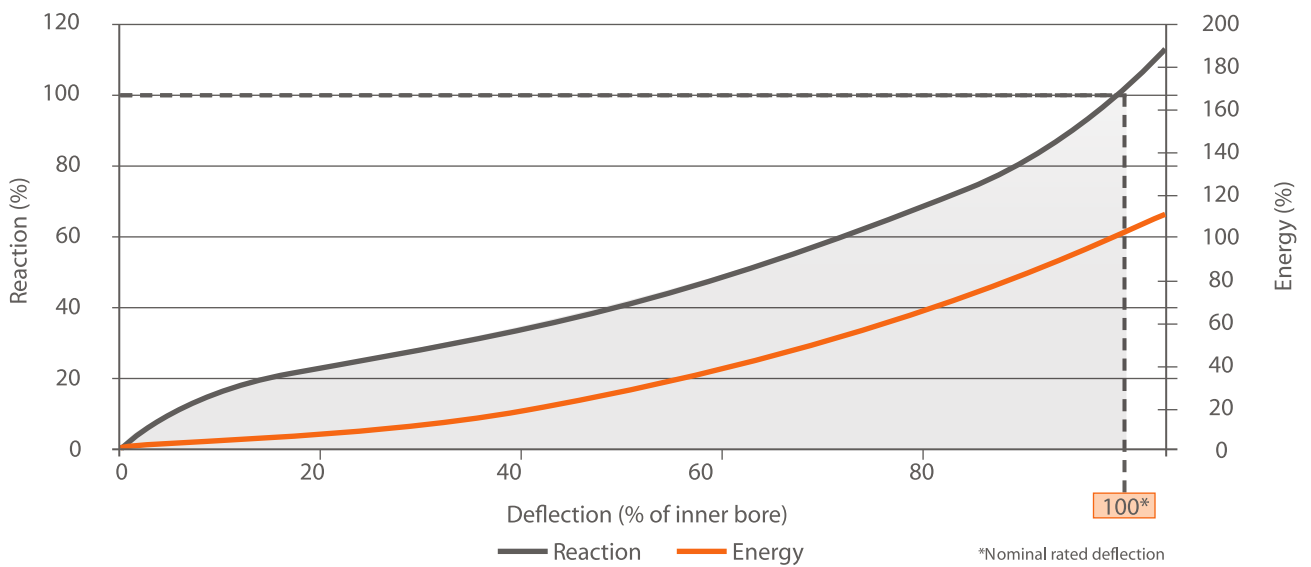

*Nominal rated deflection

D FENDERS.

DD FENDER DIMENSIONS AND PERFORMANCE VALUES

H [mm]	B [mm]	C [mm]	D1 [mm]	D2 [mm]	E [mm]	F [mm]	J* [mm]	ED* [mm]	Flat Bar [mm]	An-chors	Weight [kg/m]	Energy [kJ/m]	Reaction [kN]
100 x 100	25.0	30	18	24	25	10	200 – 300	90 – 130	40 x 5	M12	8.3	1.4	77
150 x 150	37.5	40	24	32	30	12	250 – 350	110 – 150	50 x 8	M16	18.0	3.2	115
200 x 200	50.0	50	30	40	45	15	300 – 400	130 – 180	70 x 10	M20	32.0	5.7	153
250 x 250	62.5	60	36	48	50	20	350 – 450	140 – 200	90 x 12	M24	50.0	8.9	191
300 x 300	75.0	60	36	48	60	25	350 – 450	140 – 200	100 x 12	M24	72.0	12.9	230
350 x 350	87.5	75	45	60	70	25	350 – 450	140 – 200	130 x 15	M30	103.6	17.6	268
380 x 380	95.0	75	45	60	80	30	350 – 450	140 – 200	140 x 15	M30	122.1	20.0	286
400 x 400	100.0	75	45	60	80	30	350 – 450	140 – 200	150 x 15	M30	128.0	23.0	306
500 x 500	125.0	90	54	72	90	40	400 – 500	160 – 230	180 x 20	M36	200.0	35.9	383

* For fixing details see p. 83 | Performance values for single units of 1,000 mm length

DD FENDER DRAWING

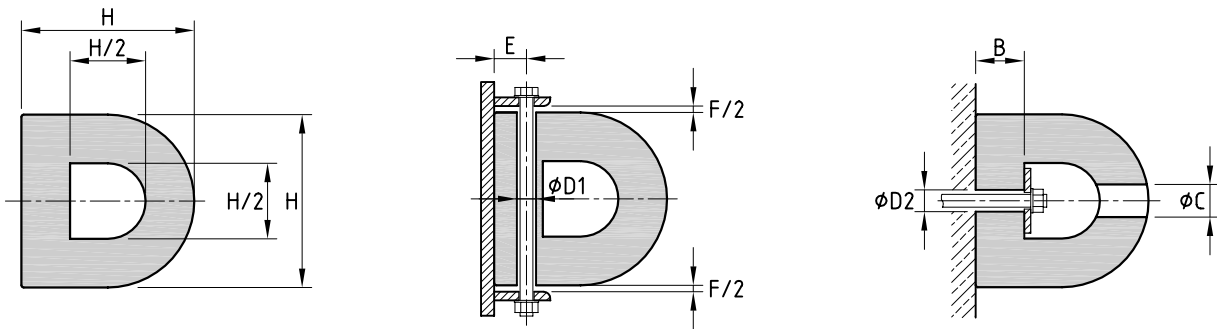

DC FENDER DIMENSIONS, PERFORMANCE VALUES AND DRAWING

H [mm]	D [mm]	E [mm]	F [mm]	J* [mm]	ED* [mm]	An-chors	Weight [kg/m]	Energy [kJ/m]	Reaction [kN]
100 x 100	18	25	10	200 – 300	90 – 130	M12	9.9	1.9	157
150 x 150	24	30	12	250 – 350	110 – 150	M16	20.0	4.2	235
200 x 200	30	45	15	300 – 400	130 – 180	M20	37.4	7.5	314
250 x 250	36	50	20	350 – 450	140 – 200	M24	57.2	11.7	392
300 x 300	36	60	25	350 – 450	140 – 200	M24	81.3	16.9	471
350 x 350	45	70	25	350 – 450	140 – 200	M30	109.5	22.9	549
400 x 400	45	80	30	350 – 450	140 – 200	M30	142.0	29.4	628
500 x 500	54	90	40	400 – 500	150 – 230	M36	208.0	46.0	785

* For fixing details see p. 83 | Performance values for single units of 1,000 mm length

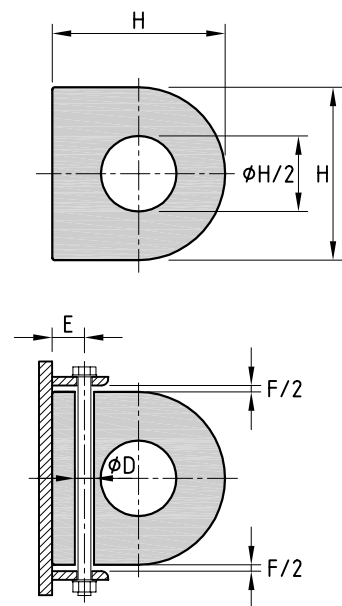

SQUARE FENDERS.

SD FENDER DIMENSIONS AND PERFORMANCE VALUES

H [mm]	B [mm]	C [mm]	D1 [mm]	D2 [mm]	E [mm]	F [mm]	J* [mm]	ED* [mm]	Flat Bar [mm]	An- chors	Weight [kg/m]	Energy [kJ/m]	Reaction [kN]
100 x 100	25.0	30	18	24	25	10	200 – 300	90 – 130	40 x 5	M12	9.5	2.7	136
150 x 150	37.5	40	24	32	30	12	250 – 350	110 – 150	50 x 8	M16	22.1	6.4	206
200 x 200	50.0	50	30	40	45	15	300 – 400	130 – 180	70 x 10	M20	38.7	11.3	275
250 x 250	62.5	60	36	48	50	20	350 – 450	140 – 200	90 x 12	M24	59.3	17.6	343
300 x 300	75.0	60	36	48	60	25	350 – 450	140 – 200	100 x 12	M24	85.0	25.5	412
350 x 350	87.5	75	45	60	70	25	350 – 450	140 – 200	130 x 15	M30	116.0	34.3	471
400 x 400	100.0	75	45	60	80	30	350 – 450	140 – 200	150 x 15	M30	148.5	45.2	589
500 x 500	125.0	90	54	72	90	40	400 – 500	160 – 230	180 x 20	M36	232.1	70.7	736

* For fixing details see p. 83 | Performance values for single units of 1,000 mm length

SD FENDER DRAWING

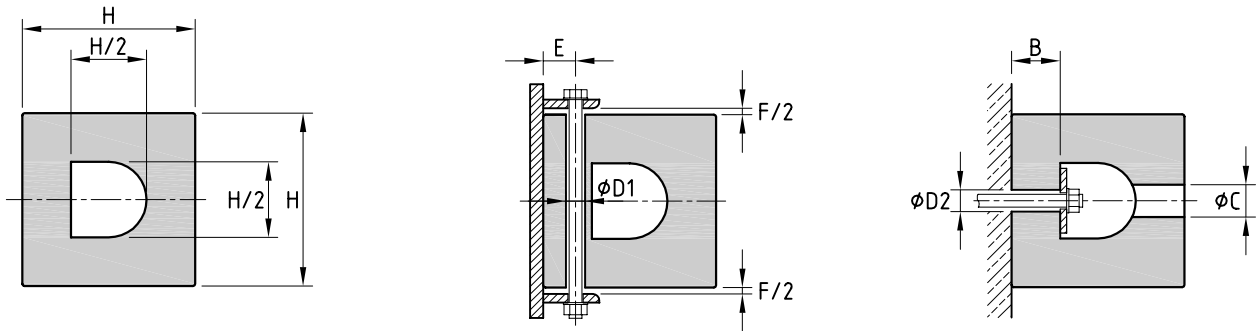

SC FENDER DIMENSIONS, PERFORMANCE VALUES AND DRAWING

H [mm]	D [mm]	E [mm]	F [mm]	J* [mm]	ED* [mm]	An- chors	Weight [kg/m]	Energy [kJ/m]	Reaction [kN]
100 x 100	18	25	10	200 – 300	90 – 130	M12	11.1	2.7	173
150 x 150	24	30	12	250 – 350	110 – 150	M16	22.9	6.4	259
200 x 200	30	45	15	300 – 400	130 – 180	M20	42.6	11.3	345
250 x 250	36	50	20	350 – 450	140 – 200	M24	65.3	17.7	431
300 x 300	36	60	25	350 – 450	140 – 200	M24	92.9	25.5	518
350 x 350	45	70	25	350 – 450	140 – 200	M30	117.6	34.3	604
400 x 400	45	80	30	350 – 450	140 – 200	M30	153.6	45.1	690
500 x 500	54	90	40	400 – 500	150 – 230	M36	240.1	70.5	863

* For fixing details see p. 83 | Performance values for single units of 1,000 mm length

