



Accessories and Fixings.

Characteristics

- ▶ High quality chains, accessories and compatible fixings
- ▶ Customized
- ▶ Wide range of materials
- ▶ Tested and certified

Chains

Chain Tensioners

Shackles & Brackets

Cast-in Anchors & Cast-in U Anchors

Chemical Anchors & Chemical U Anchors

Washers

Bolts & Nuts

SAFIM AS AGENT

CHAIN SYSTEMS.

TYPICAL CHAIN SYSTEM DRAWING

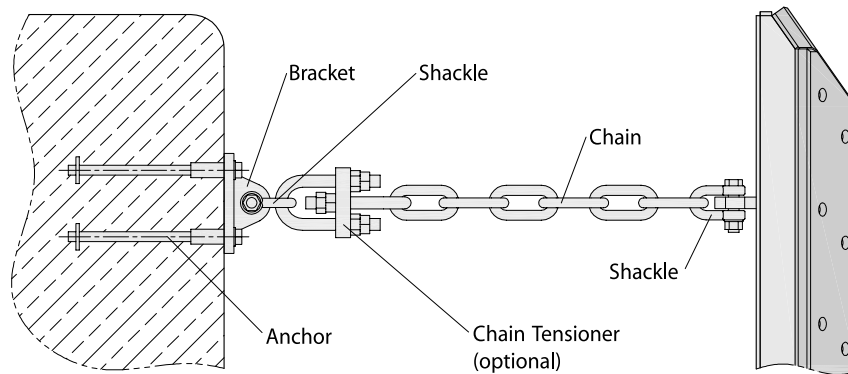

CHAIN DIMENSIONS

Chains

Ø D [mm]	Chain 4 x D				Chain 5 x D				K2 MBL [kN]	K3 MBL [kN]
	T [mm]	B1 [mm]	B2 [mm]	Weight [kg/m]	T [mm]	B1 [mm]	B2 [mm]	Weight [kg/m]		
14	56	20	48	3.8	70	21	49	3.7	124	154
16	64	22	54	5.0	80	24	56	4.8	160	202
18	72	25	61	6.3	90	27	63	6.0	209	262
20	80	28	68	7.8	100	30	70	7.5	264	330
22	88	31	75	9.4	110	33	77	9.0	304	380
25	100	35	85	12.1	125	38	88	11.6	393	491
28	112	39	95	15.2	140	42	98	14.6	492	616
30	120	42	102	17.4	150	45	105	16.7	566	706
32	128	45	109	19.8	160	48	112	19.0	644	804
35	140	49	119	23.8	175	53	123	22.8	770	964
38	152	53	129	28.0	190	57	133	26.9	900	1,130
40	160	56	136	31.0	200	60	140	29.8	1,010	1,260
45	180	63	153	39.3	225	68	158	27.7	1,275	1,590
50	200	70	170	48.5	250	75	175	46.5	1,570	1,960

Intermediate or larger sizes available upon request

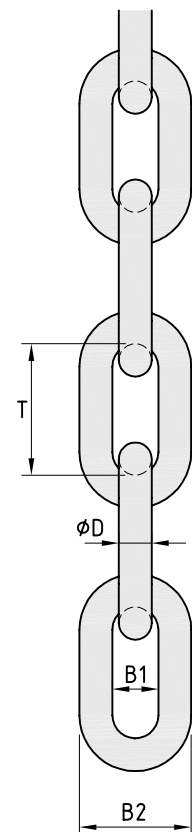

CHAIN TENSIONER DIMENSIONS

Type	A [mm]	B [mm]	X [mm]	T [mm]	Ø c [mm]	Ø a [mm]	b [mm]	Weight* [kg]
Ø 20	390	260	130	30	120	20	50	5.8
Ø 24	390	270	120	30	130	24	56	8.4
Ø 30	445	325	120	40	170	30	80	16.4
Ø 36	550	390	160	45	210	36	94	28.8
Ø 42	670	470	200	55	250	42	108	48.2
Ø 48	860	595	265	60	280	48	122	71.9
Ø 56	890	620	270	70	330	56	144	110.7
Ø 64	820	700	120	80	350	64	160	149.8



Chain Tensioner

Different adjustments (X) available upon request | The table above indicates dimensions of standard Chain Tensioners | Chain Tensioners need to be customized for every project, based on geometry and capacity of the chain system
 *Typical weights

CHAIN TENSIONER DRAWING

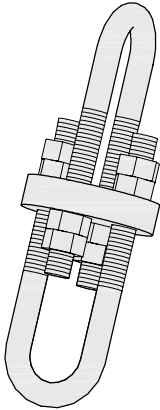
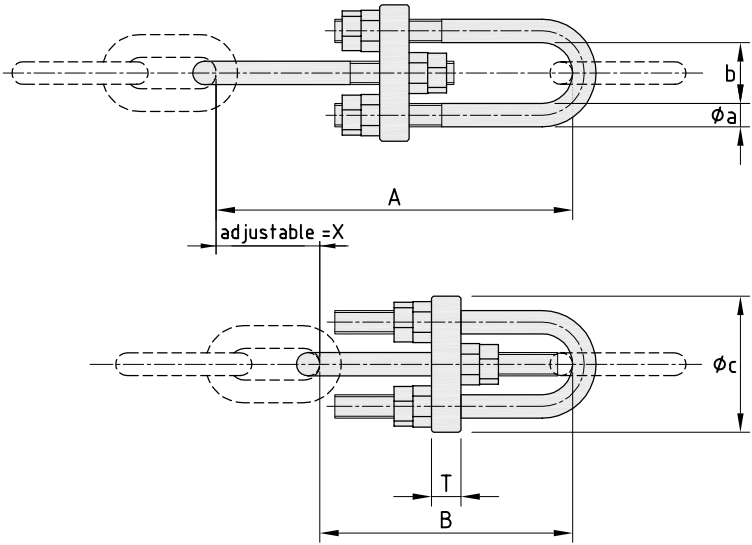

Chain Tensioner and rubber sleeves



Chain Tensioner

SHACKLE DIMENSIONS

WLL [t]	Ø A [mm]	Ø B [mm]	Ø C [mm]	E [mm]	D Type		Bow Type		
					D1 [mm]	Weight [kg]	D2 [mm]	F [mm]	Weight [kg]
2.0	13	16	34	22	43	0.4	51	32	0.4
3.25	16	19	40	27	51	0.7	64	43	0.8
4.75	19	22	47	31	59	1.1	76	51	1.3
6.5	22	25	53	36	73	1.5	83	58	1.9
8.5	25	28	60	43	85	2.6	95	68	2.8
9.5	28	32	67	47	90	3.3	108	75	3.8
12.0	32	35	74	51	94	4.7	115	83	5.3
13.5	35	38	80	57	115	6.2	133	95	7.0
17.0	38	42	84	60	127	7.6	146	99	8.8
25.0	45	50	104	74	149	12.8	178	126	15.0

Other types and sizes available upon request



D Type Shackle

GENERIC BRACKET DRAWINGS

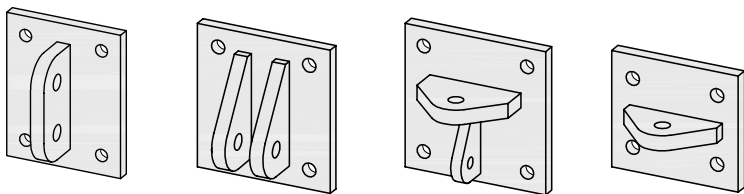

Various Bolt-on Brackets

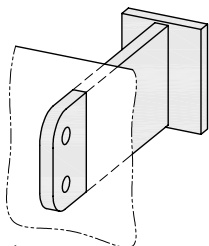

Cast-in Bracket

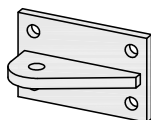

Shear Bracket

SHACKLE DRAWING S

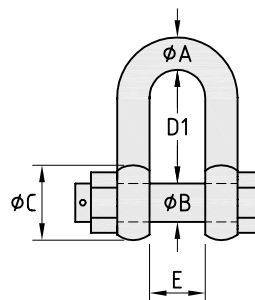

D Type

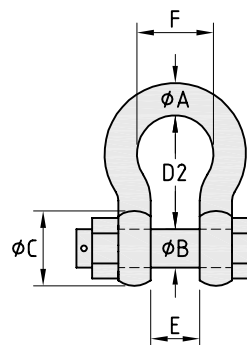

Bow Type



Shear Bracket

FIXINGS.

CAST-IN ANCHOR DIMENSIONS

Anchor Size	L [mm]	B [mm]	C [mm]	Ø D [mm]	Weight [kg]
M20	214	50	20	30	0.8
M24	258	60	25	35	1.5
M30	318	70	30	45	2.4
M36	328	80	40	55	3.7
M42	416	85	45	65	6.0
M48	431	100	50	75	9.0
M56	436	105	60	85	14.0
M64	600	128	80	100	23.0
M76	700	152	90	114	42.0



Cast-in Anchor

Other sizes available upon request

Formular to determine bolt length:

1: $A > G + F + 1.2 \times M$

2: $A < G + F + B$

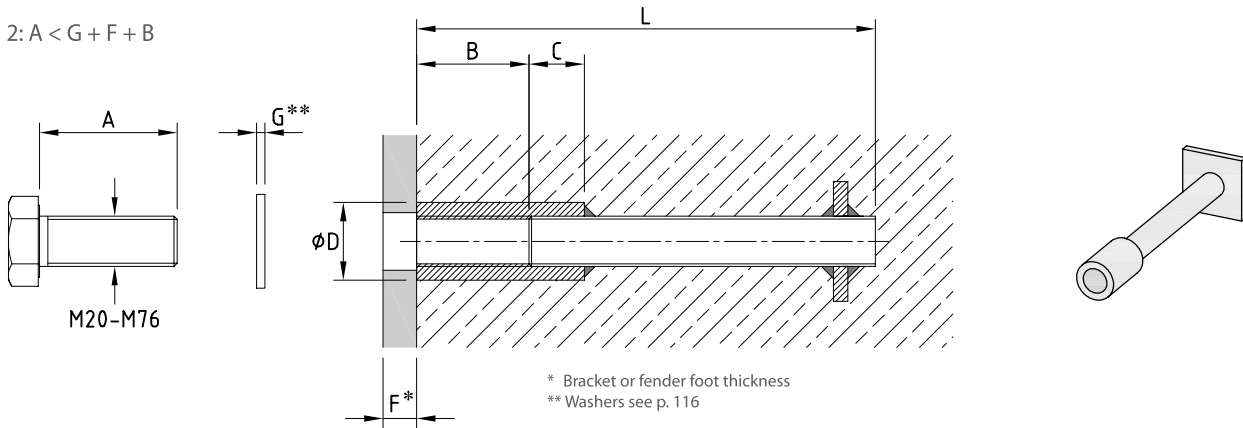

GENERIC CAST-IN U ANCHOR DRAWING

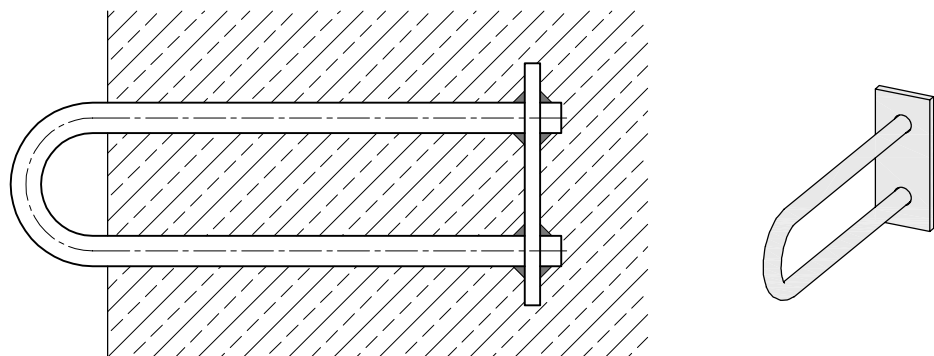

CHEMICAL ANCHOR DIMENSIONS

Anchor Size	A [mm]	Ø D [mm]	E [mm]	Grout Volume [ml]
M16	140	18	13	18
M20	170	22	16	30
M24	210	28	19	66
M30	280	35	24	130
M36	360	42	29	232
M42	420	48	34	325
M48	460	55	38	460
M56	500	62	45	550
M64	560	70	51	725
M76	670	84	61	1,200

For all cases, the required embedded depth should be checked by calculations | Other sizes available upon request



Chemical Anchor

Formular to determine bolt length:

1: req. $B = E + F + G + ca. 0.4 \times M$

2: req. $L = A + B$

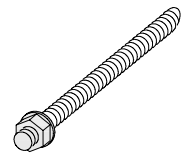
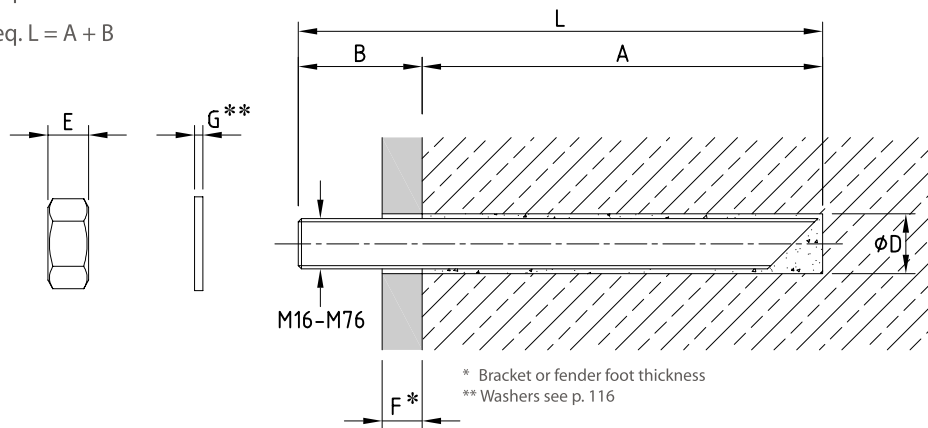

GENERIC CHEMICAL U ANCHOR DRAWING

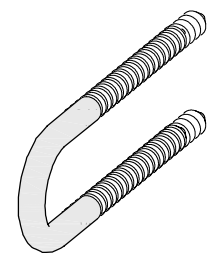
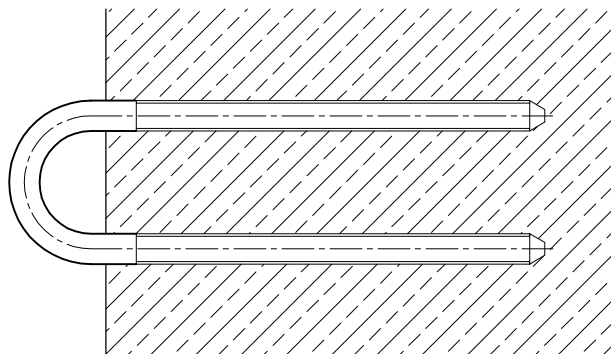

WASHER DIMENSIONS

Anchor Size	ISO 7089		Special Washer Plates for FE Element Fenders		Special Washer Plates for CSS and V Fenders				Special Washer Plates for SPC Fenders*		
	OD x ID [mm]	G [mm]	OD x ID [mm]	G [mm]	L x B [mm]	D [mm]	G [mm]	Weight [kg]	L x B [mm]	D [mm]	G [mm]
M16	30 x 17	3	-	-	-	-	-	-	-	-	-
M20	37 x 21	3	44 x 21	4	50 x 45	22	5	0.08	55 x 45	22	6
M24	44 x 25	4	56 x 25	5	75 x 55	26	6	0.15	80 x 70	26	6
M30	56 x 31	4	72 x 32	6	85 x 65	32	6	0.30	115 x 90	34	8
M36	66 x 37	5	80 x 38	8	100 x 75	38	6	0.36	165 x 130	40	8
M42	78 x 45	8	92 x 45	8	150 x 90	45	10	0.97	205 x 170	46	10
M48	92 x 52	8	105 x 52	8	175 x 100	52	10	1.26	80 x 140	52	10
M56	105 x 62	10	115 x 60	8	185 x 125	62	10	1.85	245 x 170	60	12
M64	115 x 70	10	-	-	200 x 130	70	10	2.08	-	-	10
M76	135 x 82	10	-	-	230 x 150	80	12	3.30	-	-	12

*Typical sizes | For details, refer to the project specific fender drawing

WASHER DRAWING

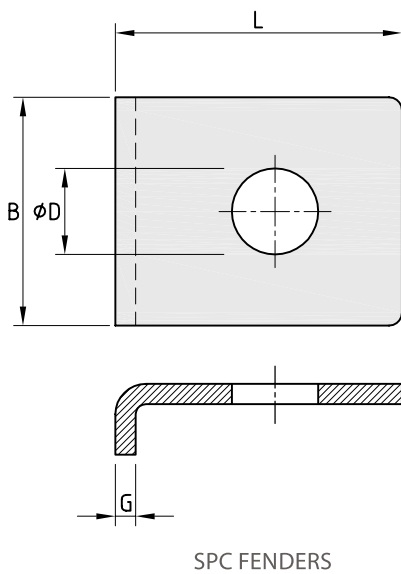
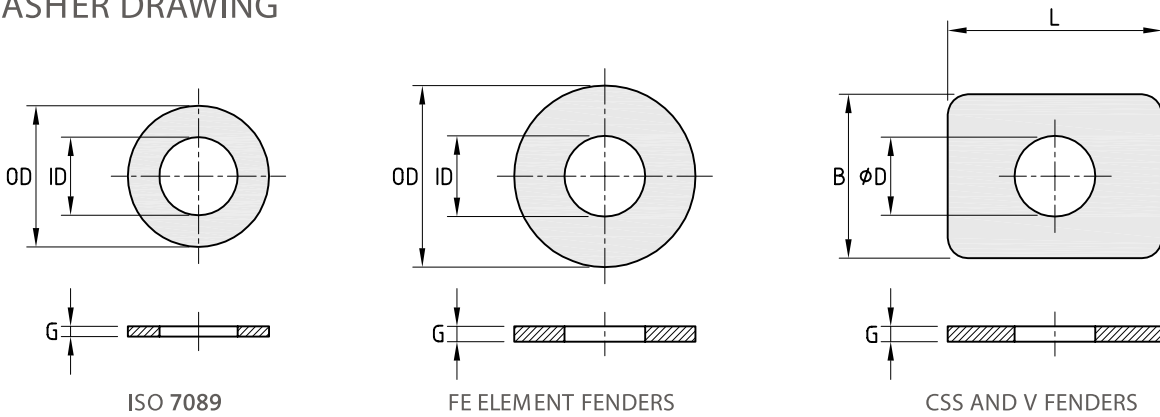

Maasvlakte II | Rotterdam | The Netherlands

BOLTS & NUTS DRAWING

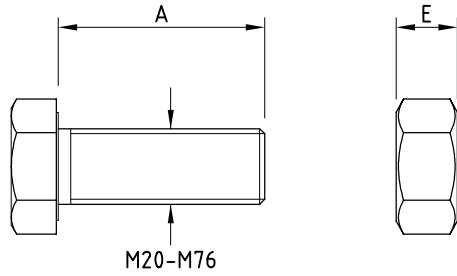

Formular to determine bolt length:

$$1: A > G + F + 1.2 \times M$$

$$2: A < G + F + B$$

For details see p. 114



Bolts & Nuts

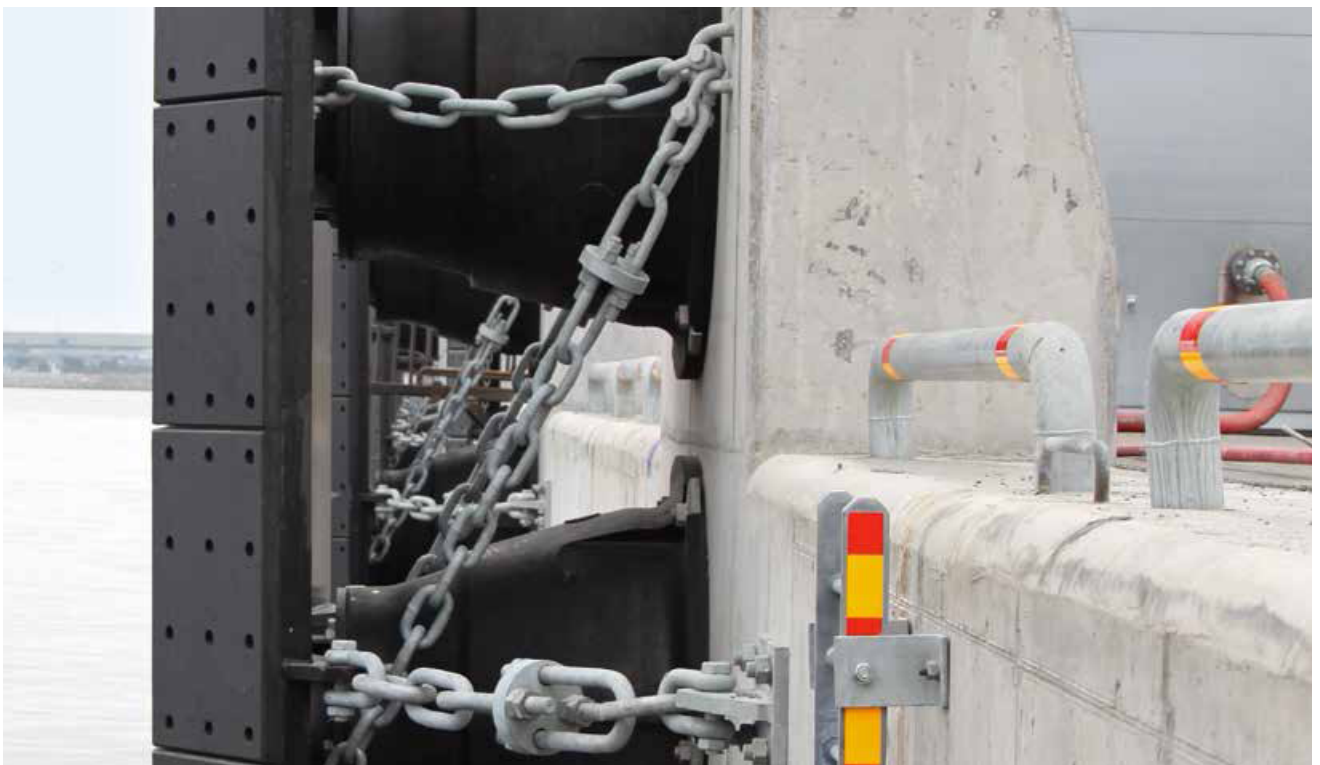

Restraint chain assemblies and brackets