



Cylindrical Fenders.

Characteristics

- ▶ Very robust and simple design
- ▶ Easy to install
- ▶ High abrasion resistance
- ▶ Proportional increase of energy and reaction

Applications

- ▶ Multiple usage at different berths
- ▶ Bulk Terminals
- ▶ General Cargo Terminals
- ▶ RoRo Terminals
- ▶ Tug Boats
- ▶ Barge

SAFIM AS AGENT

CYLINDRICAL FENDER DIMENSIONS AND PERFORMANCE VALUES

Fender Size OD x ID [mm]	E [kNm/m]	R [kN/m]	P [kN/m ²]	Weight [kg/m]
100 x 50	0.8	43	547	7
125 x 65	1.3	51	500	11
150 x 75	1.8	65	552	16
175 x 75	2.7	92	781	24
200 x 100	3.3	86	547	29
250 x 125	5.1	108	550	45
300 x 150	7.4	129	547	65
380 x 190	11.8	164	550	105
400 x 200	13.1	172	547	116
450 x 225	16.6	194	549	147
500 x 250	28.0	275	700	181
600 x 300	40.0	330	700	255
800 x 400	72.0	440	700	453
900 x 450	86.0	470	700	573
1,000 x 500	112.0	550	700	707

Fender Size OD x ID [mm]	E [kNm/m]	R [kN/m]	P [kN/m ²]	Weight [kg/m]
1,100 x 600	131.0	541	574	800
1,200 x 600	162.0	660	700	1,018
1,300 x 700	184.0	650	591	1,131
1,400 x 700	220.0	770	700	1,386
1,400 x 800	208.0	649	516	1,245
1,500 x 750	253.0	825	700	1,591
1,500 x 800	246.0	760	605	1,517
1,600 x 800	288.0	880	700	1,810
1,600 x 900	273.0	757	535	1,650
1,800 x 900	364.0	990	700	2,290
2,000 x 1,000	432.0	1,060	700	2,827
2,000 x 1,200	415.0	871	517	2,414
2,200 x 1,200	524.0	1,083	575	3,204
2,400 x 1,200	647.0	1,321	700	4,073
2,700 x 1,300	818.0	1,486	605	5,278

Performance values for single units of 1,000 mm length | Nominal rated deflection is 100 % of ID | Actual deflection at Rated Performance Data may vary | Certain sizes available as molded fenders | Intermediate sizes available upon request

CYLINDRICAL FENDER DRAWING

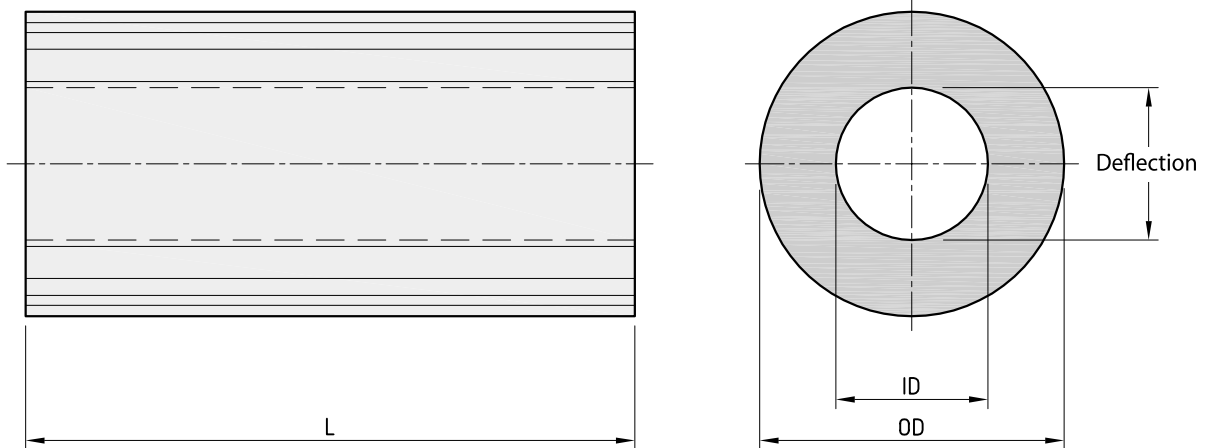



Rashid Port Berth 25 | Dubai | U.A. E.

GENERIC PERFORMANCE CURVE CYLINDRICAL FENDERS

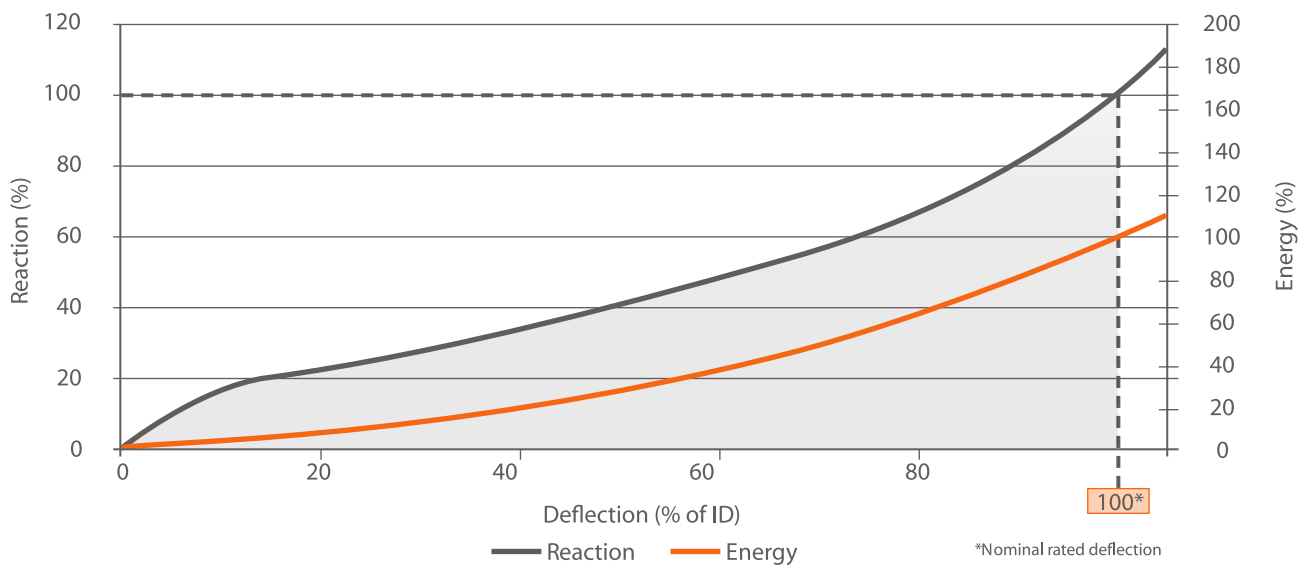

FIXING DETAILS – SMALL CYLINDRICALS

Small cylindricals (OD 600 mm) are often suspended from chains, connected to brackets or U Anchors on the quay wall. We recommend rubber sleeves over the chain to extend the lifetime of the fender.

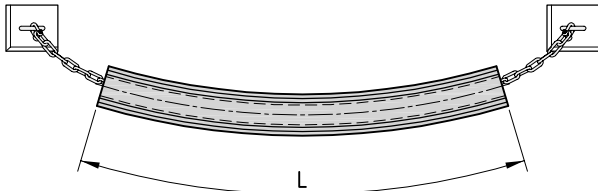

Constanta South Port | Constanța | Romania

FIXING DETAILS – LARGE CYLINDRICALS

Large cylindricals (OD 600 mm – 1,600 mm) often use a central support bar connected at each end to chains which are fixed to brackets or U Anchors on the quay wall.

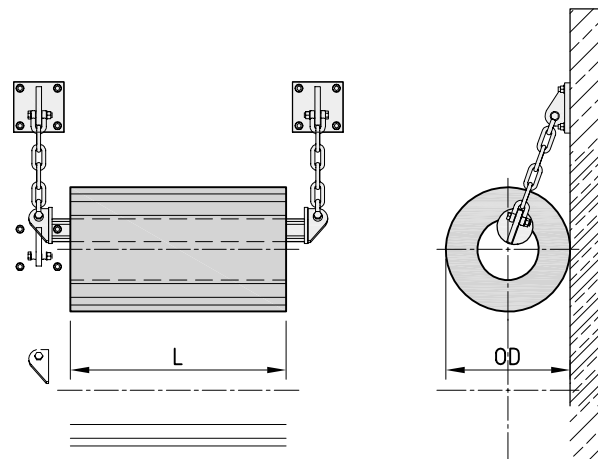

Burchardkai | Hamburg | Germany

FIXING DETAILS – VERY LARGE CYLINDRICALS

Very large cylindricals (OD 1,600 mm) may require special ladder brackets due to their weight. These are specially designed for each application.

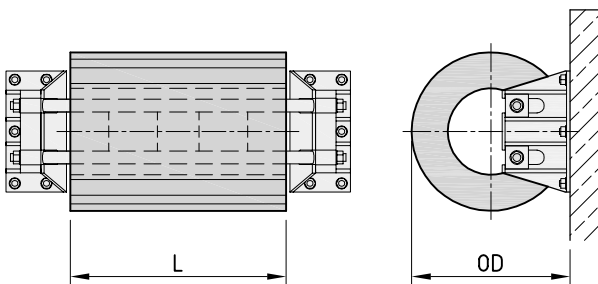

Kalkhaven | Dordrecht | The Netherlands